

# Durelloy-TGP™

## HEAT TREATED ALLOY

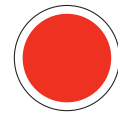

Color Code:  
ENDS RED

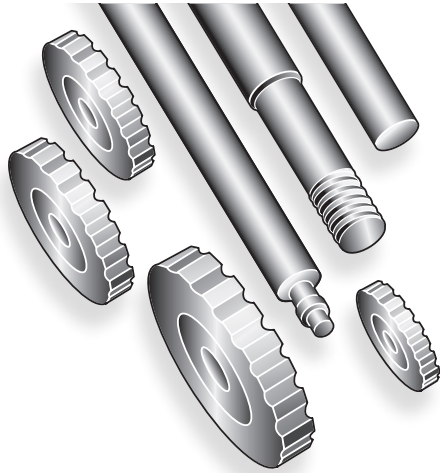

Durelloy-TGP is produced from Durelloy hot roll heat treat 28-32 Rc bars, then precision turned, ground, and flawlessly polished to exacting sizes. Durelloy-TGP eliminates costly machining to size at your plant, which helps reduce downtime. Durelloy-TGP allows you to produce long, straight keyways without bowing problems.

### Features And Advantages

- Precision tuned, ground and polished
- Not cold drawn, free from drawing stresses
- Straightness guaranteed prior to shipment
- Good weldability
- Free machining
- Ultra fine grain microstructure
- Wear resistant
- Eliminates premature fatigue/failure due to hardness and high luster
- Stress relieved

### Applications

- Arbors
- Gear shafts
- Journals
- Line shafts
- Lead screws
- Drive shafts
- Motor shafts
- Crank shafts
- Armature shafts
- Cement mill shafts
- Textile equipment
- Mining equipment
- Generator shafts
- Pinions
- Piston rods
- Push rods
- Spindles
- Feed screws
- Tie rods

### Standard Tolerances

- Standard finish of 8 micro-inches
- 1/4" to 4" diameter: +.000" to -.002" tolerance
- Over 4" diameter: +.000" to -.003" tolerance
- Closer tolerance of +/- .0005" available

*All shipments of Durelloy-TGP are specially oiled, then wrapped or tubed and delivered in perfect condition. All bars are inspected prior to shipping for straightness and tolerances.*

### Durelloy-TGP Rounds 1/8" Diameter Rounds in 1/16" Increments

1/8	3/4	1-5/16	1-7/8	2-7/16	3	4	5-15/16
3/16	13/16	1-3/8	1-15/16	2-1/2	3-1/8	4-1/4	6
1/4	7/8	1-7/16	2	2-9/16	3-3/16	4-7/16	6-1/2
5/16	15/16	1-1/2	2-1/16	2-5/8	3-1/4	4-1/2	7
3/8	1	1-9/16	2-1/8	2-11/16	3-3/8	4-3/4	8
1/2	1-1/16	1-5/8	2-3/16	2-3/4	3-7/16	4-15/16	
9/16	1-1/8	1-11/16	2-1/4	2-13/16	3-1/2	5	
5/8	1-3/16	1-3/4	2-5/16	2-7/8	3-3/4	5-7/16	
11/16	1-1/4	1-13/16	2-3/8	2-15/16	3-15/16	5-1/2	

Lengths: 20' R/L. Larger sizes and metric sizes in stock.