

Durelloy™

METRIC TGP

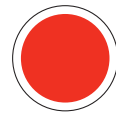

Color Code:
ENDS RED

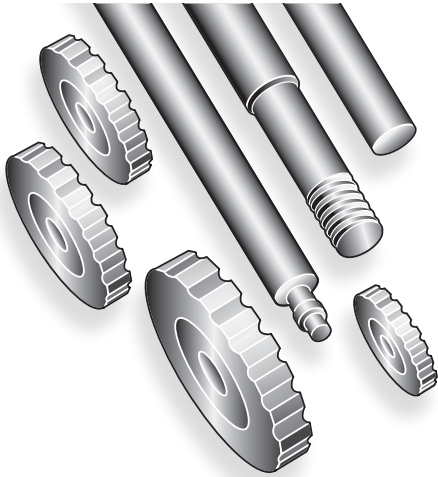

Durelloy Metric TGP is produced from Durelloy hot roll heat treat 28-32 Rc bars, then precision turned, ground, and flawlessly polished to exacting sizes. Durelloy Metric TGP eliminates costly machining to size at your plant, which helps reduce downtime. Durelloy Metric TGP allows you to produce long, straight keyways without bowing problems.

Features And Advantages

- Precision tuned, ground and polished
- Not cold drawn, free from drawing stresses
- Straightness guaranteed prior to shipment
- Good weldability
- Free machining
- Ultra fine grain microstructure
- Wear resistant
- Eliminates premature fatigue/failure due to hardness and high luster
- Stress relieved

Applications

- Arbors
- Gear shafts
- Journals
- Line shafts
- Lead screws
- Drive shafts
- Motor shafts
- Crank shafts
- Armature shafts
- Cement mill shafts
- Textile equipment
- Mining equipment
- Generator shafts
- Pinions
- Piston rods
- Push rods
- Spindles
- Feed screws
- Tie rods

Standard Tolerances

- 1mm to 100mm +.000" to -.002"
- Over 100mm +.000" to -.003"
- Closer tolerances available upon request

Durelloy Metric TGP Rounds

4 mm	17 mm	30 mm	50 mm
5 mm	18 mm	31 mm	60 mm
6 mm	19 mm	32 mm	65 mm
7 mm	20 mm	33 mm	70 mm
8 mm	21 mm	34 mm	80 mm
9 mm	22 mm	35 mm	
10 mm	23 mm	36 mm	
11 mm	24 mm	37 mm	
12 mm	25 mm	38 mm	
13 mm	26 mm	39 mm	
14 mm	27 mm	40 mm	
15 mm	28 mm	41 mm	
16 mm	29 mm	45 mm	

Lengths: 12' R/L. Larger sizes in stock.

All shipments are specially oiled, wrapped or tubed, and delivered in perfect condition. All bars are inspected prior to shipping for straightness and tolerances.